

DuPont de Nemours (Luxembourg) S.à r.l.

Rue General Patton
L-2984
Luxembourg

Tel: 01275 337660 Fax: 01275 879033
e-mail: tyvek.construction@lux.dupont.com
website: www.tyvek.co.uk



Agrément Certificate
90/2548
Product Sheet 3

TYVEK CONSTRUCTION MEMBRANES

TYVEK REFLEX INSULATING BREATHER MEMBRANE

PRODUCT SCOPE AND SUMMARY OF CERTIFICATE

This Certificate relates to the TYVEK Reflex Insulating Breather Membrane, a low emissivity, insulating, breather membrane for external walls in timber-frame constructions.

AGRÉMENT CERTIFICATION INCLUDES:

- factors relating to compliance with Building Regulations where applicable
- factors relating to additional non-regulatory information where applicable
- independently verified technical specification
- assessment criteria and technical investigations
- design considerations
- installation guidance
- regular surveillance of production
- formal three-yearly review.

KEY FACTORS ASSESSED

Weathertightness — the product will contribute to protecting a wall against water penetration (see section 5).

Thermal insulation — the product can contribute to limiting heat loss through a wall (see section 6 and BBA Information Bulletin No 5 *Reflective breather membranes in timber frame walls — Thermal performance claims*).

Risk of condensation — the product has a low resistance to water vapour transmission (see section 7).

Strength — the product has adequate strength to resist damage during the construction of the wall (see section 8).

Durability — the product will have a life equal to that of the building in which it is installed (see sections 5.2 and 11).



The BBA has awarded this Agrément Certificate to the company named above for the product described herein. This product has been assessed by the BBA as being fit for its intended use provided it is installed, used and maintained as set out in this Certificate.

On behalf of the British Board of Agrément

Simon Wroe
Head of Approvals — Materials

Greg Cooper
Chief Executive

Date of Fourth issue: 5 October 2011

Originally certified on 27 September 2004

The BBA is a UKAS accredited certification body — Number 113. The schedule of the current scope of accreditation for product certification is available in pdf format via the UKAS link on the BBA website at www.bbacerts.co.uk

Readers are advised to check the validity and latest issue number of this Agrément Certificate by either referring to the BBA website or contacting the BBA direct.

British Board of Agrément
Bucknalls Lane
Garston, Watford
Herts WD25 9BA

tel: 01923 665300
fax: 01923 665301
e-mail: mail@bba.star.co.uk
website: www.bbacerts.co.uk

©2011

Regulations

In the opinion of the BBA, the TYVEK Reflex Insulating Breather Membrane, if used in accordance with the provisions of this Certificate, will meet or contribute to meeting the relevant requirements of the following Building Regulations:



The Building Regulations 2010 (England and Wales)

Requirement: C2(b)	Resistance to moisture
Comment:	The product will contribute to a wall meeting this Requirement. See section 5.1 of this Certificate.
Requirement: C2(c)	Resistance to moisture
Comment:	The product can contribute to limiting the risk of interstitial condensation. See sections 7.5 and 7.9 of this Certificate.
Requirement: L1(a)(i)	Conservation of fuel and power
Comment:	The product can contribute to meeting this Requirement. See sections 6.1 to 6.4 of this Certificate.
Requirement: Regulation 7	Materials and workmanship
Comment:	The product is acceptable. See section 11 and the <i>Installation</i> part of this Certificate.



The Building (Scotland) Regulations 2004 (as amended)

Regulation: 8(1)	Fitness and durability of materials and workmanship
Comment:	The product satisfies the requirements of this Regulation. See section 11 and the <i>Installation</i> part of this Certificate.
Regulation: 9	Building standards – construction
Standard: 3.10	Precipitation
Comment:	The product will contribute to a wall satisfying this Standard, with reference to clauses 3.10.1 ⁽¹⁾⁽²⁾ and 3.10.5 ⁽¹⁾⁽²⁾ of this Standard. See section 5.1 of this Certificate.
Standard: 3.15	Condensation
Comment:	The product can contribute to limiting the risk of interstitial condensation, with reference to clauses 3.15.1 ⁽¹⁾⁽²⁾ , 3.15.4 ⁽¹⁾⁽²⁾ and 3.15.5 ⁽¹⁾⁽²⁾ of this Standard. See sections 7.5 and 7.10 of this Certificate.
Standard: 6.1(b)	Carbon dioxide emissions
Standard: 6.2	Building insulation envelope
Comment:	The product can contribute to a wall satisfying the requirements of this Standard, with reference to clauses 6.1.1 ⁽¹⁾ , 6.1.2 ⁽²⁾ , 6.1.3 ⁽¹⁾ , 6.1.6 ⁽¹⁾ , 6.2.1 ⁽¹⁾⁽²⁾ , 6.2.3 ⁽¹⁾ , 6.2.4 ⁽¹⁾⁽²⁾ , 6.2.5 ⁽²⁾ , 6.2.6 ⁽¹⁾⁽²⁾ , 6.2.7 ⁽¹⁾ , 6.2.8 ⁽¹⁾⁽²⁾ , 6.2.9 ⁽¹⁾⁽²⁾ , 6.2.10 ⁽¹⁾⁽²⁾ , 6.2.11 ⁽¹⁾⁽²⁾ , 6.2.12 ⁽²⁾ and 6.2.13 ⁽¹⁾⁽²⁾ of these Standards. See sections 6.1 to 6.4 of this Certificate.
Standard: 7.1(a)(b)	Statement of sustainability
Comment:	The product can contribute to meeting the relevant requirements of Regulation 9, Standards 1 to 6 and therefore will contribute to a construction meeting a bronze level of sustainability as defined in this Standard. In addition the product can contribute to a construction meeting a higher level of sustainability as defined in this Standard, with reference to clauses 7.1.4 ⁽¹⁾⁽²⁾ , 7.1.6 ⁽¹⁾⁽²⁾ and 7.1.7 ⁽¹⁾⁽²⁾ Aspects 1 and 2 (see sections 6.1 to 6.4 of this Certificate).
Regulation: 12	Building standards – conversions
Comment:	Comments made in relation to the product under Regulation 9, Standards 1 to 6 also apply to this Regulation, with reference to clause 0.12.1 ⁽¹⁾⁽²⁾ and Schedule 6 ⁽¹⁾⁽²⁾ . (1) Technical Handbook (Domestic). (2) Technical Handbook (Non-Domestic).



The Building Regulations (Northern Ireland) 2000 (as amended)

Regulation: B2	Fitness of materials and workmanship
Comment:	The product is acceptable. See section 11 and the <i>Installation</i> part of this Certificate.
Regulation: C4(b)	Resistance to ground moisture and weather
Comment:	The product will contribute to a wall satisfying this Regulation. See section 5.1 of this Certificate.
Regulation: C5	Condensation
Comment:	The product can contribute to limiting the risk of interstitial condensation. See section 7.5 of this Certificate.
Regulation: F2(a)(i)	Conservation measures
Regulation: F3(2)	Target carbon dioxide Emission Rate
Comment:	The product can contribute to satisfying these Regulations. See sections 6.1 to 6.4 of this Certificate.

Construction (Design and Management) Regulations 2007

Construction (Design and Management) Regulations (Northern Ireland) 2007

Information in this Certificate may assist the client, CDM co-ordinator, designer and contractors to address their obligations under these Regulations.

See section: 1 *Description* (1.2) of this Certificate.

Non-regulatory Information

NHBC Standards 2011

NHBC accepts the use of the TYVEK Reflex Insulating Breather Membrane, when installed and used in accordance with this Certificate, in relation to *NHBC Standards, Chapter 6.2 External timber framed walls.*

General

TYVEK is a registered trademark of E.I. du Pont de Nemours & Co or its affiliates.

Technical Specification

1 Description

1.1 The TYVEK Reflex Insulating Breather Membrane is a low emissivity insulating breather membrane and comprises a spunbonded polyethylene membrane, metallised and lacquered on one face.

1.2 The product has the nominal characteristics of:

Thickness (mm)	0.22
Mass per unit area ($\text{g}\cdot\text{m}^{-2}$)	83
Roll length (m)	100
Roll width (m)	0.48, 1.5, 2.4, 2.7
Tensile strength (N per 50 mm)	
longitudinal	250
transverse	210
Elongation at break (%)	
longitudinal	10
transverse	13
Hydrostatic head (cm of H_2O)	>200
Colour	silver outward facing surface/white inward facing surface with red logo

1.3 Air and Vapour Control Layers (AVCLs) can be used in conjunction with this product. See Product Sheets 4 and 5 of this Certificate.

1.4 Ancillary items for use with the product include:

- TYVEK Metallised Tape — a single-sided tape for sealing joints and making good
- TYVEK Butyl Tape — a double-sided butyl sealant tape for bonding the membrane to other materials, such as timber, masonry and metal
- TYVEK Double-sided Tape — a double-sided acrylic tape for sealing joints.

1.5 Quality control checks are carried out on the incoming materials, during production and on the finished product.

2 Delivery and site handling

2.1 The membrane is delivered to site in rolls with paper wrappings bearing the marketing company's name, the grade identification, the technical specifications, installation instructions and the BBA identification mark incorporating the number of this Certificate.

2.2 Rolls should be stored on their side, on a smooth, clean surface, under cover and protected from sunlight.

Assessment and Technical Investigations

The following is a summary of the assessment and technical investigations carried out on the TYVEK Reflex Insulating Breather Membrane.

Design Considerations

3 General

3.1 The TYVEK Reflex Insulating Breather Membrane is suitable for use as a radiant barrier in walls of timber-frame constructions, either factory or site applied.

3.2 In the absence of other guidance, suitable timber frame constructions are defined as those designed and built in accordance with *NHBC Standards, Chapter 6.2.*

3.3 The product meets the NHBC requirements for sites defined as Very Severe exposure.

- 3.4 The product is effective in improving the U value (thermal transmittance) of timber-framed walls.
- 3.5 The product is breathable and will limit the risk of condensation within the timber-frame wall structure.
- 3.6 The membrane may be damaged by high winds, careless handling or by long-term exposure to UV and should not be left uncovered for longer than is absolutely necessary.

4 Practicability of installation

The product can be installed readily by operatives experienced with this type of product.

5 Weathertightness



5.1 The product resists liquid water penetration and wind-blown snow and will protect the sheathing and frame from external moisture (see section 1.5, Table for *Physical properties*).

5.2 The period prior to the installation of the brickwork should be kept to a minimum.

6 Thermal insulation



6.1 Calculations of thermal transmittance (U value) should be carried out in accordance with BS EN ISO 6946 : 2007 and BRE report (BR 443 : 2006), *Conventions for U-value calculations* using an emissivity value of 0.12 for the foil surface of the product. Where this faces into a vertical vented cavity (≥ 20 mm thick) this corresponds to a cavity thermal resistance value of $0.54 \text{ m}^2 \cdot \text{K} \cdot \text{W}^{-1}$. See BBA Information Bulletin No 5. For a ventilated cavity an effective boundary layer resistance value R_{se} should be taken as $0.33 \text{ m}^2 \cdot \text{K} \cdot \text{W}^{-1}$.

6.2 Calculations for an example wall⁽¹⁾ in Table 1 show that the product improves the U value when compared to the same wall with a standard (non reflective) breather membrane.

Table 1 Example U values ($\text{W} \cdot \text{m}^{-2} \cdot \text{K}^{-1}$) for a timber-frame wall with brick outer leaf⁽¹⁾

Breather membrane type	Insulation conductivity between studs ($\text{W} \cdot \text{m}^{-1} \cdot \text{K}^{-1}$)		
	0.032	0.034	0.037
Non reflective	0.32	0.33	0.35
Tyvek Reflex	0.29	0.29	0.31

(1) Construction of wall as follows: 12.5 mm plasterboard approximately $0.25 \text{ W} \cdot \text{m}^{-1} \cdot \text{K}^{-1}$, 110 mm studs (15% bridging), 12 mm OSB sheathing, 50 mm vented cavity, 102 mm brickwork.

6.3 The product can contribute to maintaining, continuity of thermal insulation at junctions and openings.

6.4 For Accredited Construction Details the corresponding ψ values in BRE Information Paper IP 1/06 *Assessing the effects of thermal bridging at junctions and around openings*, Table 3 may be used in carbon emission calculations in Scotland and Northern Ireland. Detailed guidance for other junctions and on limiting heat loss by air infiltration can be found in:

England and Wales — Approved Documents to Part L and for new thermal elements to existing buildings, Accredited Construction Details (version 1.0). See also SAP 2009 *The Government's Standard Assessment Procedure for Energy Rating of Dwellings*, Appendix K and the SBEM User Manual for new-build.

Scotland — Accredited Construction Details (Scotland)

Northern Ireland — Accredited Construction Details (version 1.0).

7 Risk of condensation

7.1 Conventional timber-frame walls designed in accordance with BS 5250 : 2002 and incorporating the product will adequately minimise the risk of condensation.

7.2 The use of the product does not preclude the normal precautions against the formation of condensation, especially in rooms expected to have high humidity.

7.3 Convective water transfer into the wall construction can be reduced by installing an AVCL behind the internal lining. This may also contribute to a successful pressure test by achieving the required design air permeability of $10 \text{ m}^3 \cdot \text{h}^{-1} \cdot \text{m}^{-2}$ in accordance with Approved Document L (see section 1.3.3 of this Certificate).

Interstitial condensation

7.4 The product, although metallised, is perforated and therefore, vapour open. It can be used in timber-frame constructions installed on sheathing as a direct replacement for a traditional breather membrane.



7.5 Vapour resistance test results indicate a range of values for the membrane of between 0.2 to $0.4 \text{ MN} \cdot \text{s} \cdot \text{g}^{-1}$, the BBA recommend that a value of $0.28 \text{ MN} \cdot \text{s} \cdot \text{g}^{-1}$ be used for design purposes and is classified as a breather membrane in accordance with BS 5250 : 2002. Walls incorporating the product will therefore adequately limit the risk of interstitial condensation when designed and constructed in accordance with BS 5250 : 2002, Section 8.3 and Appendix D (see also section 7.8 and section 1.5, Table for *Physical properties*) of this Certificate.

7.6 The risk of condensation occurring within the wall of a timber-frame building will depend upon the properties and vapour resistance of other materials used in the construction, the internal and external conditions and the effectiveness of the AVCL.

7.7 The risk of interstitial condensation is greatest when the building is drying out after construction. Guidance on preventing condensation from this and other sources is given in BRE Digest 369 *Interstitial condensation and fabric degradation* and BRE report (BR 262 : 2002) *Thermal insulation: avoiding risks*.

7.8 The product has additional insulating properties, see section 6.1, and will maintain the frame sheathing at a higher temperature than for the same construction incorporating a conventional breather membrane. This will in turn assist in limiting the risk of interstitial condensation arising from breaches/imperfections in the AVCL in the wall's internal lining. However, it must not be relied upon as an alternative to conventional good practice for maintaining integrity of the AVCL.

Surface condensation



7.9 Walls incorporating the product will adequately limit the risk of surface condensation when the thermal transmittance (U value) does not exceed $0.7 \text{ W}\cdot\text{m}^{-2}\cdot\text{K}^{-1}$ at any point and the junctions and openings are designed in accordance with the relevant requirements of *Limiting thermal bridging and air leakage : Robust construction details for dwellings and similar buildings* TSO 2002 or BRE Information Paper IP 1/06.



7.10 Walls incorporating the product will adequately limit the risk of surface condensation when designed in accordance with BS 5250 : 2002 and when the thermal transmittance (U value) does not exceed $1.2 \text{ W}\cdot\text{m}^{-2}\cdot\text{K}^{-1}$ at any point. Additional guidance may be obtained from BRE Report (BR 262 : 2002).

8 Strength

8.1 The product will resist the loads associated with construction and installation into timber-frame constructions.

8.2 The product is not adversely affected by water and will retain its properties when wet (see section 1.5, Table for *Physical properties* and section 1.5.2).

9 Properties in relation to fire

9.1 The product will have similar properties to polyolefin membranes in relation to fire, tending to burn and shrink away from the heat source. The product is unclassifiable in terms of the Building Regulations and this should be considered when assessing the overall fire risk.

9.2 Cavity barriers should be used to satisfy the requirements of the national Buildings Regulations.

10 Maintenance

As the product is confined within a wall construction and it has suitable durability (see section 1.1), maintenance is not required. Any damaged areas should be repaired, replaced before completion in accordance with section 1.4.

11 Durability



The TYVEK Reflex Insulating Breather Membrane will be unaffected by the normal conditions found in a timber-frame wall and will have a life comparable with other elements of construction (such as vapour control layers).

Installation

12 General

TYVEK Reflex Insulating Breather Membrane must be installed in accordance with the marketing company's instructions and the recommendations given in *NHBC Standards*, Chapter 6.2, where appropriate.

13 Procedure

Lapping and jointing

13.1 The membrane should be fixed with the silver side facing the outer leaf/cladding and in such a way as to shed water away from the sheathing, and below the lowest timber. Upper layers should be lapped over lower layers.

13.2 Horizontal laps should be at least 100 mm and vertical laps 150 mm. Vertical laps should be staggered wherever possible (see Figure 1).

13.3 To assist in achieving the design air permeability the lap joints and penetrations through the membrane can be sealed with TYVEK Metallised Tape, TYVEK Double-sided Tape or TYVEK Butyl Tape (see section 1.4).

Fixing

13.4 The membrane must be secured at regular intervals with non-ferrous staples or nails to prevent damage by wind (see Figures 2, 3 and 4). The fixing intervals are horizontally at 600 mm centres or at stud positions or vertically at 300 mm centres or at 150 mm centres at openings, at vertical membrane joints and at the end of panels.

Figure 1 Laps (dimensions in mm)

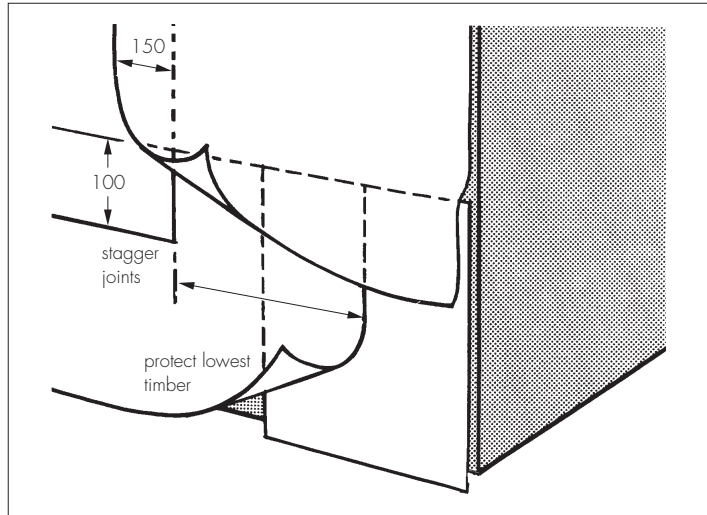

Figure 2 Factory method of installation on timber-frame panel

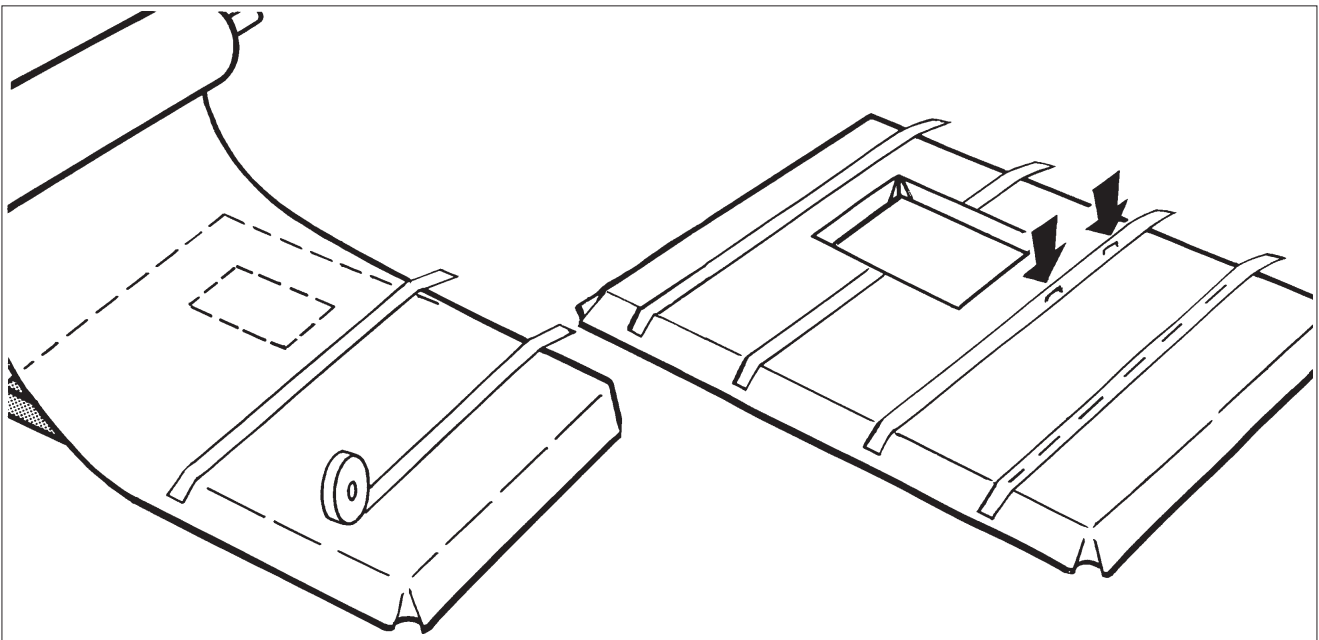

Figure 3 Site installation — external corner

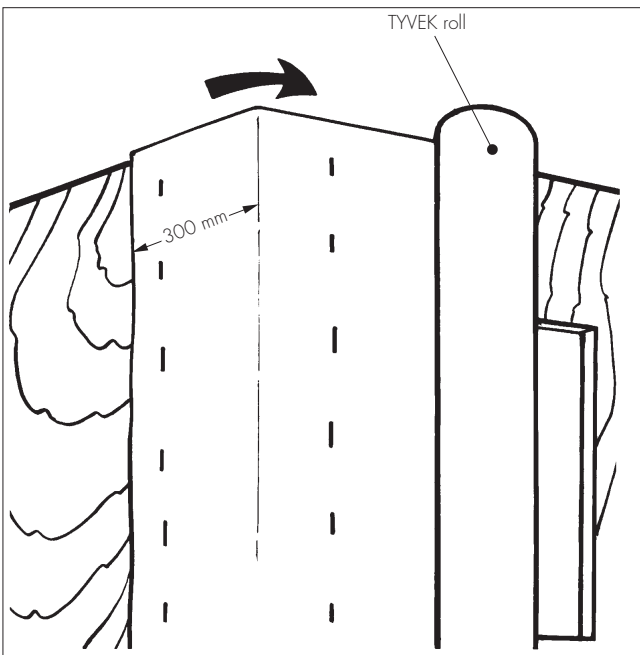
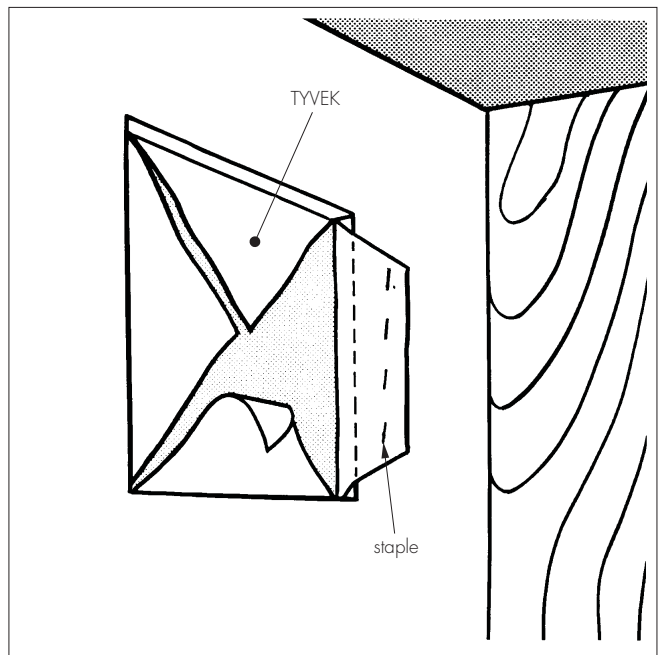

Figure 4 Site installation — opening



13.5 Nails must be corrosion resistant and staples should be stainless steel.

Marking stud positions

13.6 It is essential that the positions of studs are marked to enable wall tie fixing.

Lowest timbers

13.7 It is essential that the lowest timbers in the wall are protected by the breather membrane.

14 Repair

Damage to the membrane can be repaired prior to the installation of the external walls or cladding by laying another sheet over the damaged area and sealing it correctly, ensuring water is shed away from the sheathing.

Technical Investigations

15 Tests

15.1 Tests were conducted on samples of the TYVEK Reflex Insulating Breather Membrane and the results were assessed by the BBA (see Table 2).

Tests (units)	Mean result	Method
Water vapour transmission ($\text{g}\cdot\text{m}^{-2}\cdot\text{day}^{-1}$)	742	BS 3177 (25°C/75% RH)
Vapour resistance ($\text{MN}\cdot\text{s}\cdot\text{g}^{-1}$)	0.28	BS 3177 (25°C/75% RH)
Mullen burst strength ($\text{kN}\cdot\text{m}^{-2}$)	870	BS 3137
1 metre head of water	pass	MOAT 27 : 5.1.4.2
Resistance to water penetration (Eosin test)	pass	BS 4016

15.2 Emissivity testing was carried out on control, UV aged, heat aged and heat and humidity aged samples. All samples remained within the Certificate holder's declared value.

15.3 The following tests were carried out on a product of similar specification and assessed as being satisfactory:

- tensile strength
- elongation
- resistance to tear (nail)
- resistance to tear (trouser)
- UV ageing
- heat ageing
- water soak.

16 Investigations

16.1 An assessment of U values and risk of interstitial condensation of completed wall constructions was carried out.

16.2 The methods of quality control were evaluated and details obtained of the quality and composition of the materials used.

Bibliography

BS 3137 : 1972 *Methods for determining the bursting strength of paper and board*

BS 3177 : 1959 *Method for determining the permeability to water vapour of flexible sheet materials used for packaging*

BS 4016 : 1997 *Specification for flexible building membranes (breather type)*

BS 5250 : 2002 *Code of practice for control of condensation in buildings*

BS EN ISO 6946 : 2007 *Building components and building elements — Thermal resistance and thermal transmittance — Calculation method*

MOAT No 27 : 1983 *General Directive for the Assessment of Roof Waterproofing Systems*

17 Conditions

17.1 This Certificate:

- relates only to the product/system that is named and described on the front page
- is issued only to the company, firm, organisation or person named on the front page — no other company, firm, organisation or person may hold or claim that this Certificate has been issued to them
- is valid only within the UK
- has to be read, considered and used as a whole document — it may be misleading and will be incomplete to be selective
- is copyright of the BBA
- is subject to English Law.

17.2 Publications, documents, specifications, legislation, regulations, standards and the like referenced in this Certificate are those that were current and/or deemed relevant by the BBA at the date of issue or reissue of this Certificate.

17.3 This Certificate will remain valid for an unlimited period provided that the product/system and its manufacture and/or fabrication, including all related and relevant parts and processes thereof:

- are maintained at or above the levels which have been assessed and found to be satisfactory by the BBA
- continue to be checked as and when deemed appropriate by the BBA under arrangements that it will determine
- are reviewed by the BBA as and when it considers appropriate.

17.4 The BBA has used due skill, care and diligence in preparing this Certificate, but no warranty is provided.

17.5 In issuing this Certificate, the BBA is not responsible and is excluded from any liability to any company, firm, organisation or person, for any matters arising directly or indirectly from:

- the presence or absence of any patent, intellectual property or similar rights subsisting in the product/system or any other product/system
- the right of the Certificate holder to manufacture, supply, install, maintain or market the product/system
- individual installations of the product/system, including their nature, design, methods, performance, workmanship and maintenance
- any works and constructions in which the product/system is installed, including their nature, design, methods, performance, workmanship and maintenance
- any loss or damage, including personal injury, howsoever caused by the product/system, including its manufacture, supply, installation, use, maintenance and removal.

17.6 Any information relating to the manufacture, supply, installation, use, maintenance and removal of this product/system which is contained or referred to in this Certificate is the minimum required to be met when the product/system is manufactured, supplied, installed, used, maintained and removed. It does not purport in any way to restate the requirements of the Health and Safety at Work etc. Act 1974, or of any other statutory, common law or other duty which may exist at the date of issue or reissue of this Certificate; nor is conformity with such information to be taken as satisfying the requirements of the 1974 Act or of any statutory, common law or other duty of care.